

4

3

2

1

3/8 IN HEX INPUT CONFIGURATION

REVISION HISTORY			
REV.	DESCRIPTION	DATE	DRAWN BY
1	ORIGINAL PRINT	4/14/2025	P. YEUNG
2	ADDED BEVEL SPACER (NEVEREST HEX)	1/30/2026	P. YEUNG

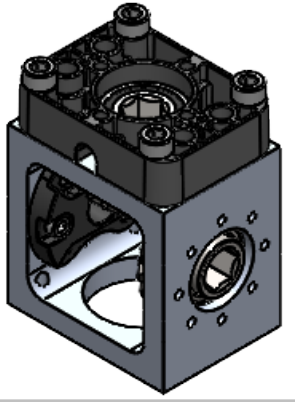
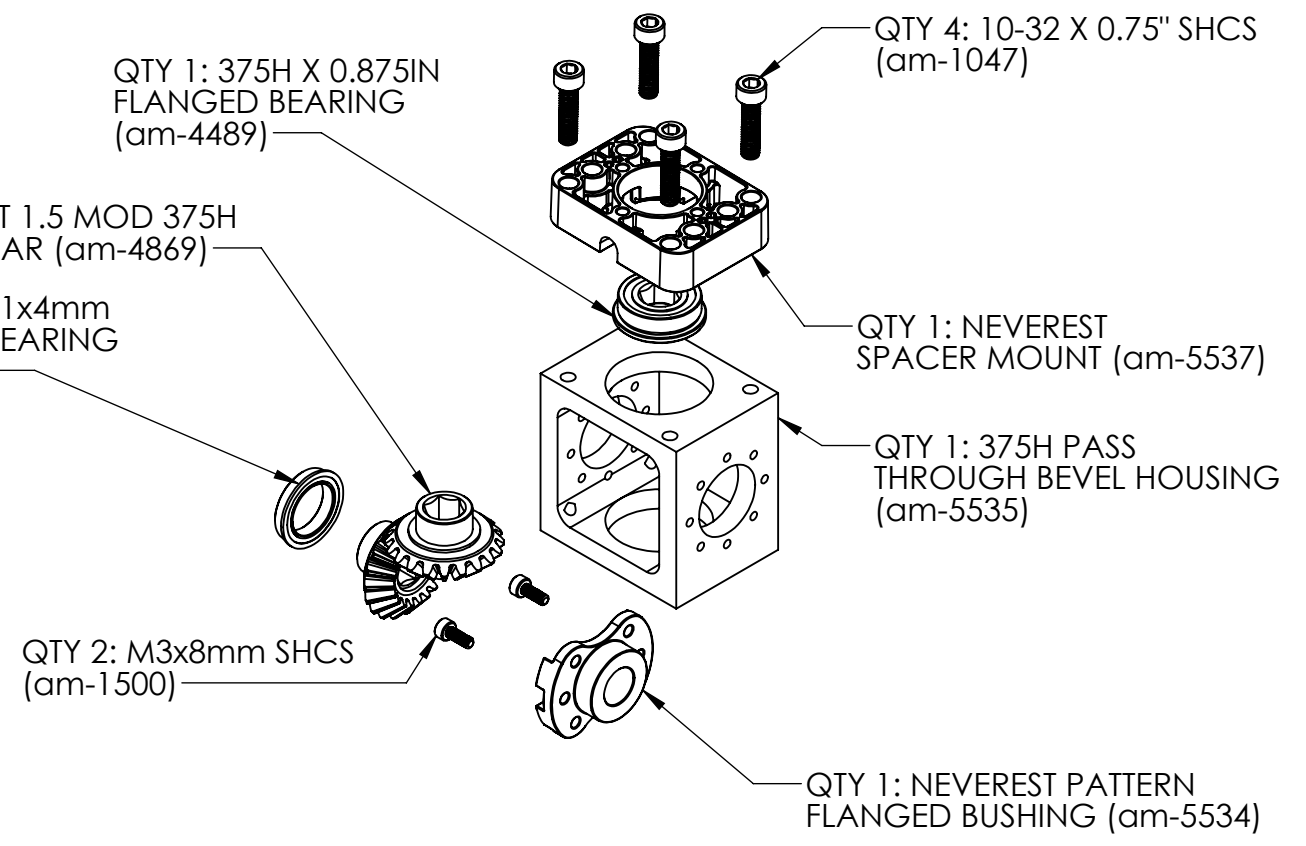
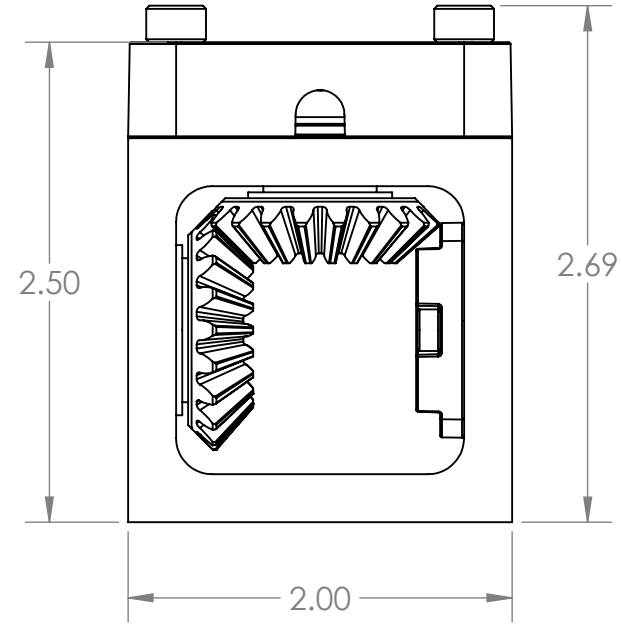
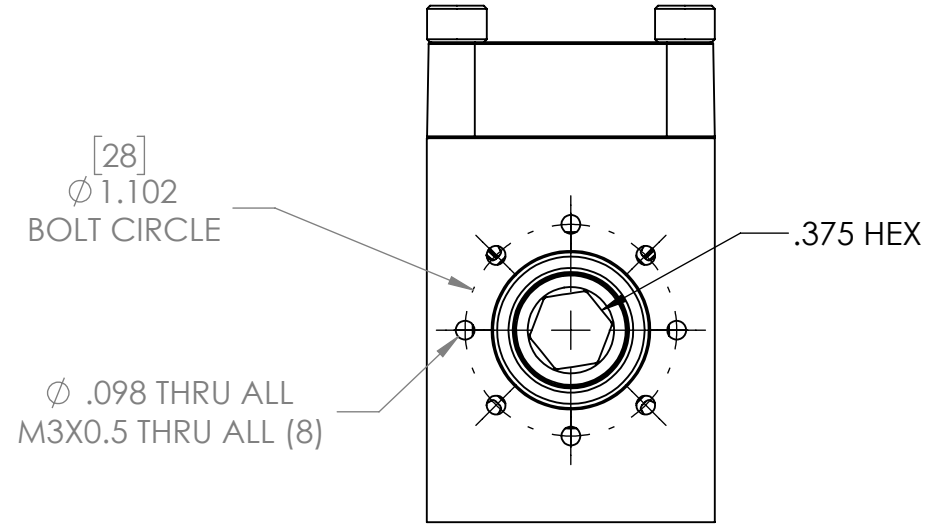
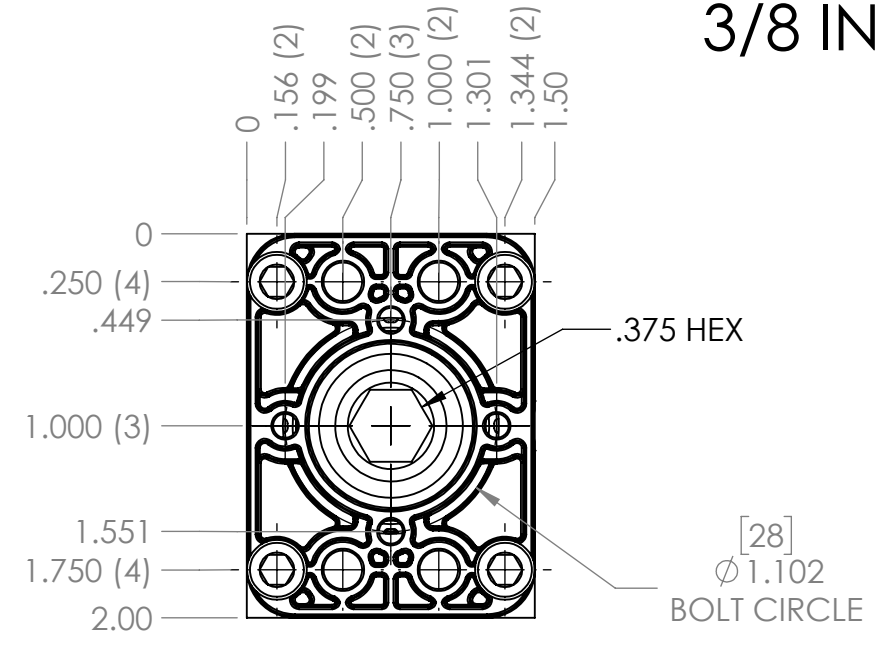

*** SEE CAD FOR ADDITIONAL TOOLPATH INFO***

UNLESS OTHERWISE SPECIFIED:		COMMENTS:				
DIMENSIONS ARE IN INCHES		DUAL DIMENSIONS ARE IN MILLIMETERS.				
TOLERANCES:		BREAK ALL SHARP EDGES.		SIZE DWG. NO. REV		
FRACTIONAL	$\pm 1/16$			B am-5475 2		
ANGULAR: MACH	$\pm 1^\circ$			SCALE: 1:1 SHEET 1 OF 3		
ANGULAR: BEND	$\pm 5^\circ$					
ONE PLACE DECIMAL	± 0.1					
TWO PLACE DECIMAL	± 0.01					
THREE PLACE DECIMAL	± 0.005					
FOUR PLACE DECIMAL	± 0.0005					
MATERIAL	VARIOUS	CHECKED	NAME	DATE		
FINISH		ENG APPR.	NM	1/30/26		
DO NOT SCALE DRAWING		MFG APPR.				
		Q.A.				

4

3

2

1

4

3

2

1

NEVEREST HEX CONFIGURATION

REVISION HISTORY			
REV.	DESCRIPTION	DATE	DRAWN BY
1	ORIGINAL PRINT	4/14/2025	P. YEUNG
2	ADDED BEVEL SPACER (NEVEREST HEX)	1/30/2026	P. YEUNG

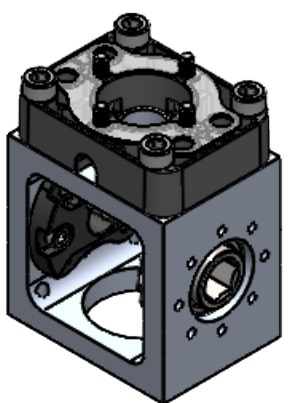
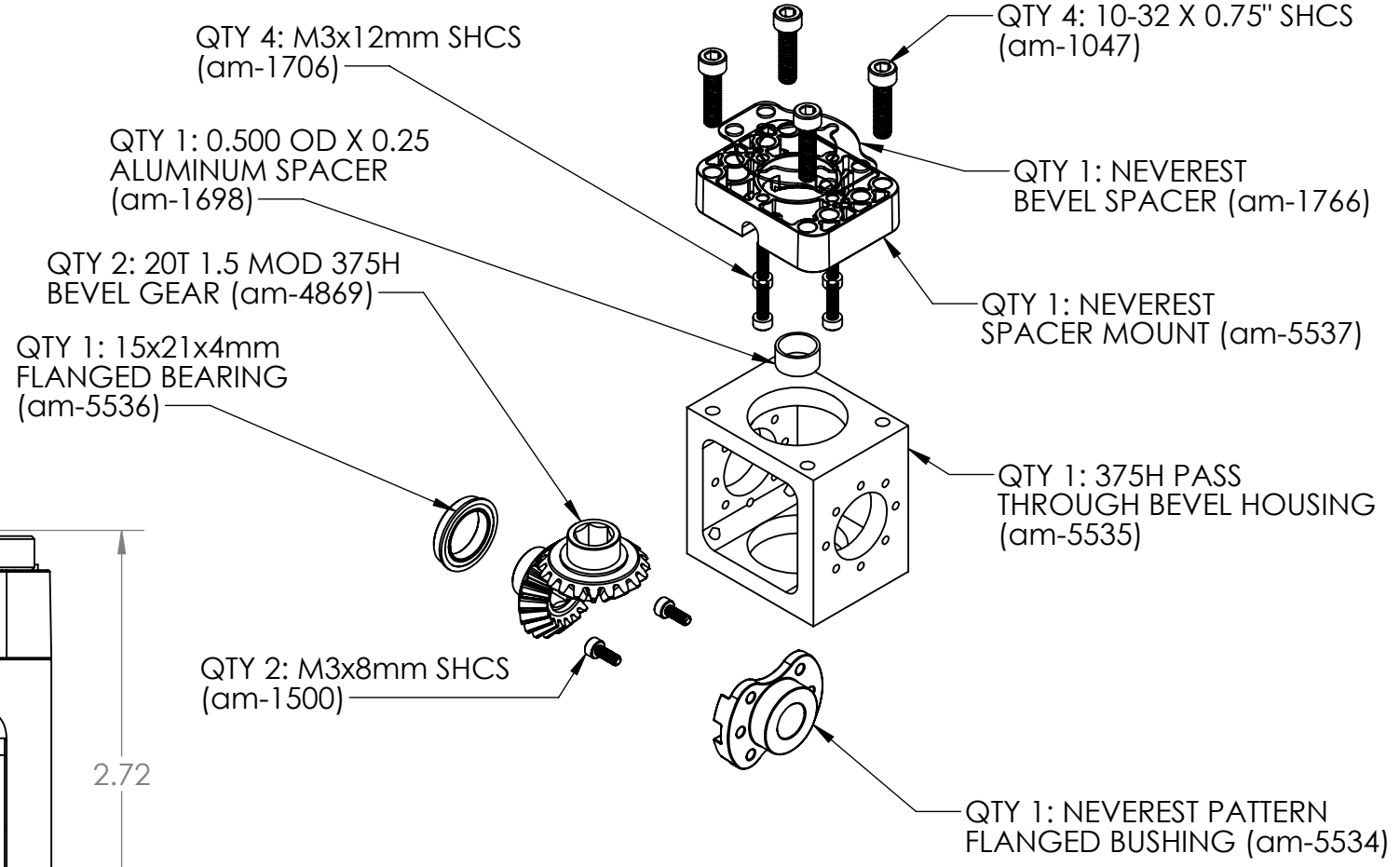
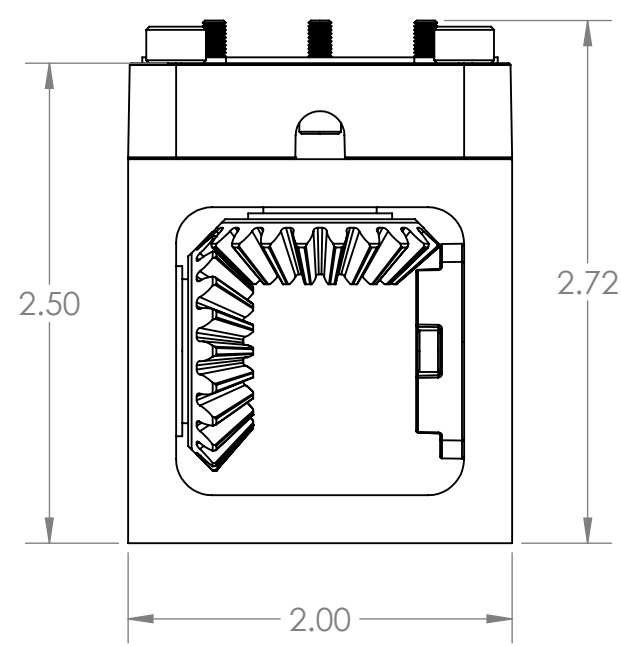
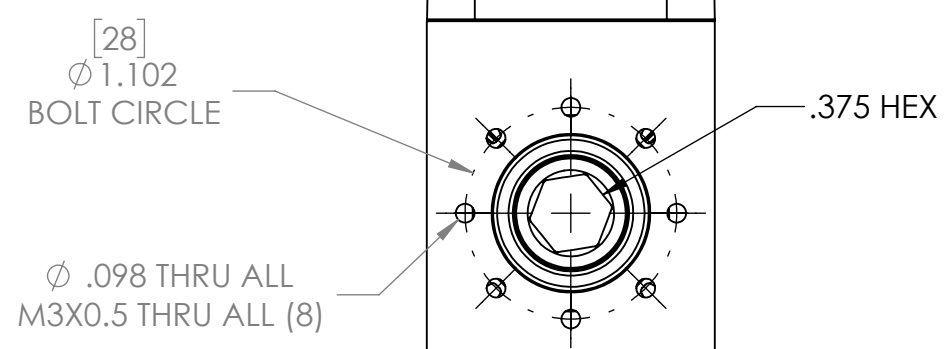
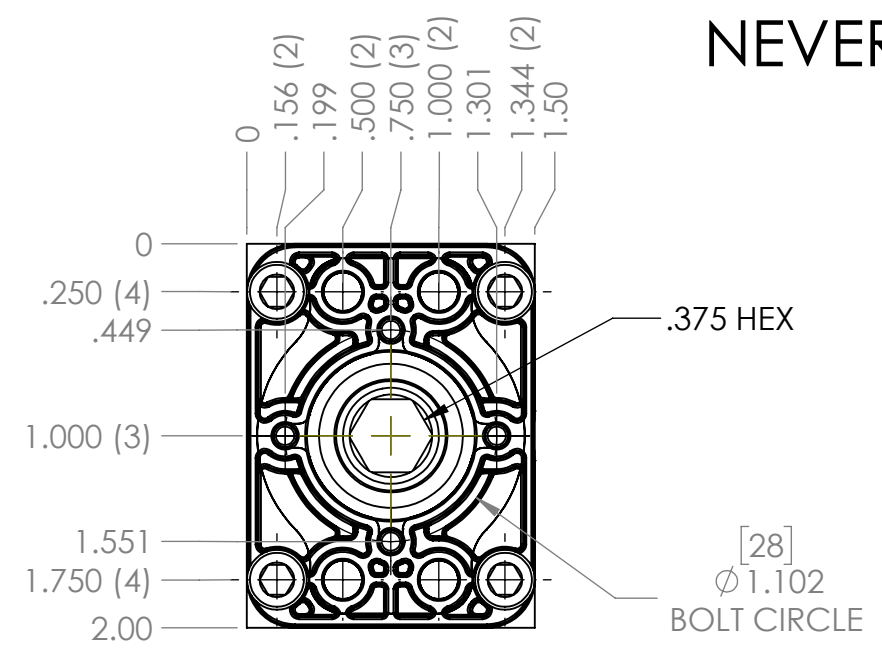

*** SEE CAD FOR ADDITIONAL TOOLPATH INFO***

UNLESS OTHERWISE SPECIFIED:		COMMENTS:				
DIMENSIONS ARE IN INCHES		DUAL DIMENSIONS ARE IN MILLIMETERS.				
TOLERANCES:		BREAK ALL SHARP EDGES.		SIZE DWG. NO. REV		
FRACTIONAL	±1/16			B am-5475 2		
ANGULAR: MACH	±1°			SCALE: 1:1 SHEET 2 OF 3		
ANGULAR: BEND	±5°					
ONE PLACE DECIMAL	±0.1					
TWO PLACE DECIMAL	±0.01					
THREE PLACE DECIMAL	±0.005					
FOUR PLACE DECIMAL	±0.0005					
MATERIAL	VARIOUS	CHECKED	NAME	DATE		
FINISH		ENG APPR.	NM	1/30/26		
		MFG APPR.				
		Q.A.				
DO NOT SCALE DRAWING						

4

3

2

1

B

B

A

A

4

3

2

1

NEVEREST ORBITAL CONFIGURATION

REVISION HISTORY			
REV.	DESCRIPTION	DATE	DRAWN BY
1	ORIGINAL PRINT	4/14/2025	P. YEUNG
2	ADDED BEVEL SPACER (NEVEREST HEX)	1/30/2026	P. YEUNG

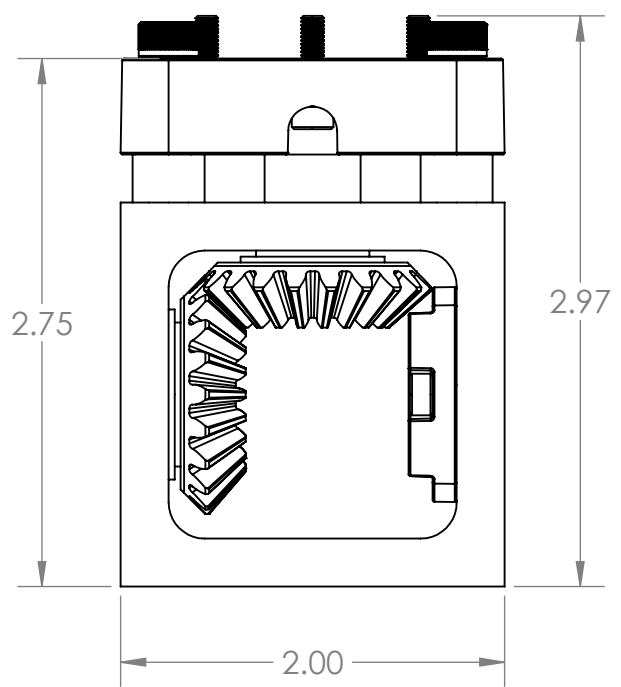
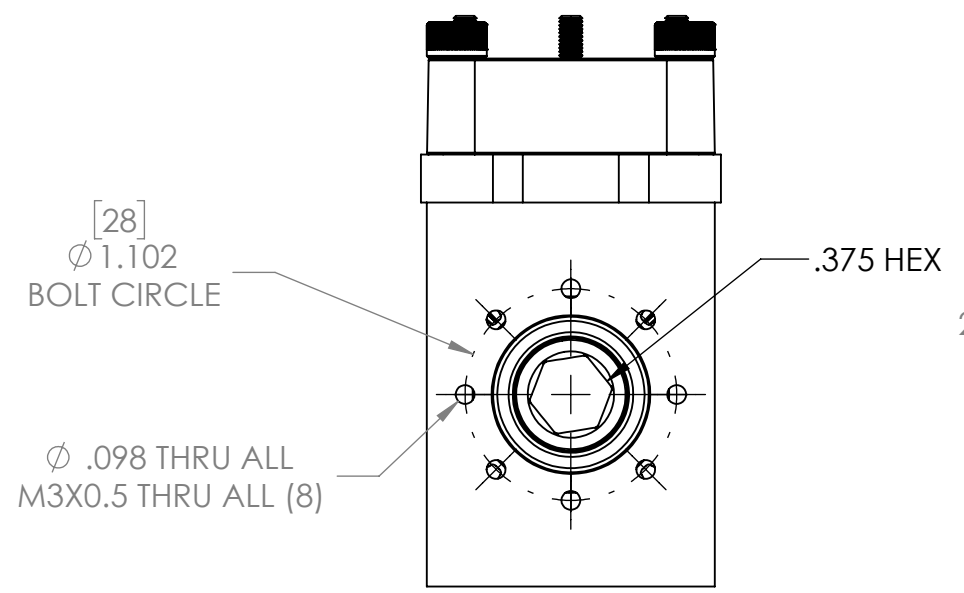
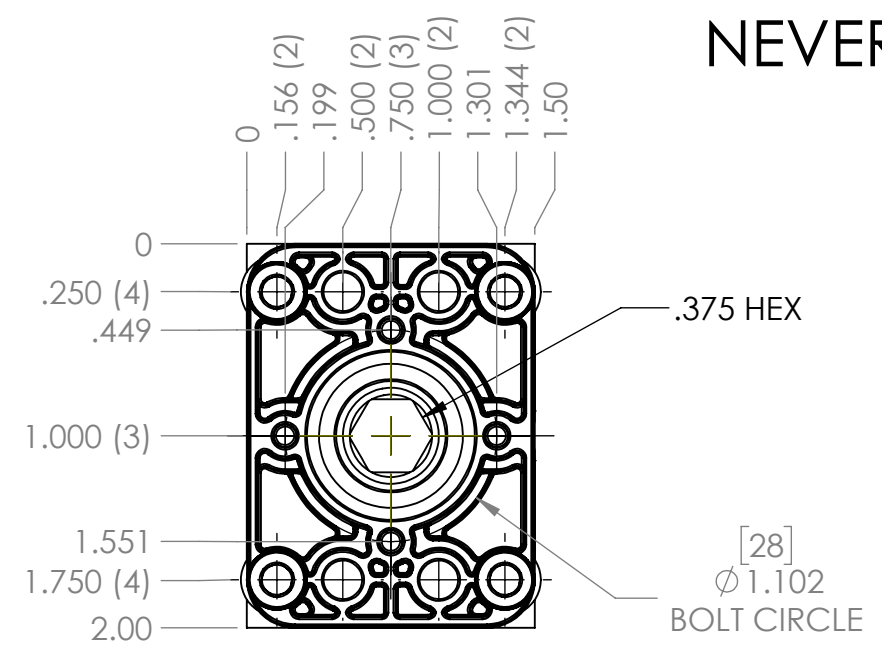

QTY 4: M3x12mm SHCS (am-1706)

QTY 4: 10-32 X 1.00" SHCS (am-1056)

QTY 4: 0.375 OD X 0.25 NYLON SPACER (am-1700)

QTY 1: 0.500 OD X 0.25 ALUMINUM SPACER (am-1698)

QTY 2: 20T 1.5 MOD 375H BEVEL GEAR (am-4869)

QTY 1: 15x21x4mm FLANGED BEARING (am-5536)

QTY 2: M3x8mm SHCS (am-1500)

QTY 1: NEVEREST SPACER MOUNT (am-5537)

QTY 1: 375H PASS THROUGH BEVEL HOUSING (am-5535)

QTY 1: NEVEREST PATTERN FLANGED BUSHING (am-5534)

*** SEE CAD FOR ADDITIONAL TOOLPATH INFO***

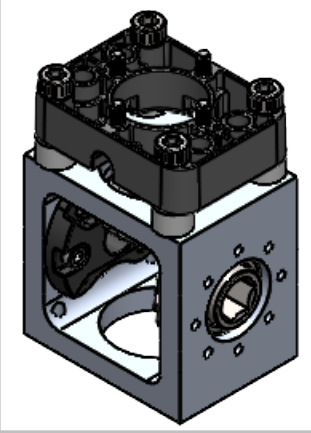

UNLESS OTHERWISE SPECIFIED:		COMMENTS:				
DIMENSIONS ARE IN INCHES		DUAL DIMENSIONS ARE IN MILLIMETERS.				
TOLERANCES:		BREAK ALL SHARP EDGES.		SIZE DWG. NO. REV		
FRACTIONAL	±1/16			B am-5475 2		
ANGULAR: MACH	±1°			SCALE: 1:1 SHEET 3 OF 3		
ANGULAR: BEND	±5°					
ONE PLACE DECIMAL	±0.1					
TWO PLACE DECIMAL	±0.01					
THREE PLACE DECIMAL	±0.005					
FOUR PLACE DECIMAL	±0.0005					
MATERIAL	VARIOUS	CHECKED	NAME	DATE		
FINISH		ENG APPR.	NM	1/30/26		
DO NOT SCALE DRAWING		MFG APPR.				
		Q.A.				

4

3

2

1

B

B

A

A